

《ULTRASPAN》

Inclined Plate Clarifier

Model: IPC



Inclined Plate Clarifier (IPC), which also known as lamella plate clarifier is designed to remove particulates from water. IPC is ideal for applications, where the solids loading is variable and solid sizing is fine. Unlike conventional clarifiers, IPC consists of a series of closely spaced flat plates inclined at an angle of from 55 to 60 degrees from horizontal. These inclined plates provide a large effective settling area for a small footprint. The inlet stream is stilled upon entry into the clarifier. Solid particles begin to settle on the plates and begin to accumulate in collection hoppers at the bottom of the clarifier unit. The sludge is drawn off at the bottom of this hopper and the clarified water exits the unit at the top by weir.

The main advantage of IPC over other clarification process is the large effective settling area caused by the use of inclined plates, which improves the operating conditions of the clarifiers in a number of ways. The unit is more compact usually requiring only 65-80 % of the area of clarifiers operating without inclined plates. Therefore, where site footprint constraints are of concern a lamella clarifier system is preferred. The reduced required area allows the possibility for the clarifiers to be located and operated indoor, reducing some of the common problems of algae growth, clogging due to blowing debris accumulation and odour control, that occur when the machinery is outdoors. Operation within an enclosed space also allows for a better control of operating temperature and pressure conditions.

Applications

- Potable water
- Process water
- Industrial effluent
- Scrubber wastewater

Benefits

- Low capital cost
- Compact footprint
- Easy installation
- Simple maintenance

Standard Features

- FRP or SS304 material
- Flange connection
- Access platform (option)
- Flash mixer chamber (option)
- Chemical feed system (option)

IPC Model Selection :

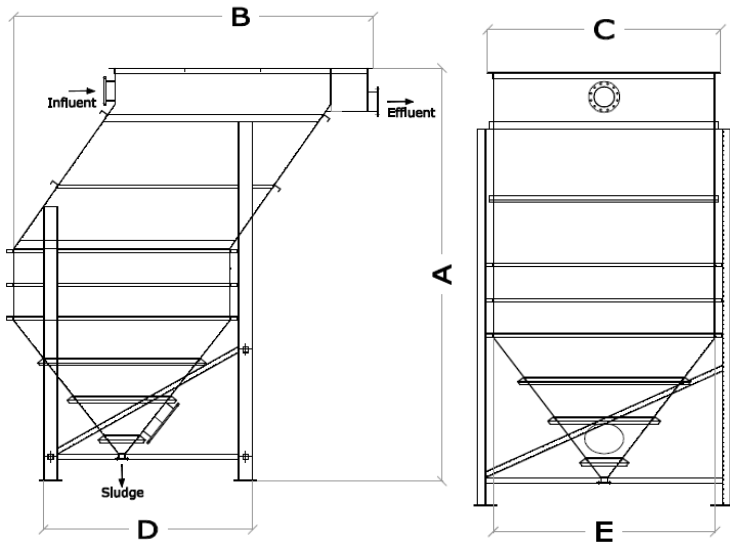

Model No.	A	B	C	D	E
IPC 7/55	3785	2850	1200	1450	1200
IPC 13/55	3785	3100	1200	1700	1200
IPC 25/55	3785	3100	1800	1700	1800
IPC 40/55	4235	3940	1800	1700	1870
IPC 60/55	4235	4239	1800	2000	1870
IPC 80/55	5450	4100	2220	2000	2290
IPC 100/55	6200	4100	2420	2000	2490
IPC 120/55	6430	4100	2900	2000	2950
IPC 140/55	6430	4400	2900	2300	2950
IPC 165/55	6430	4800	2900	2700	2950

$$\text{IPC Flow Rate (m}^3\text{/hr)} = \text{Total Effective Area (m}^2\text{)} \times \text{Upflow Velocity (m/hr)}$$

*** Recommended upflow velocity = 0.4 m/hr (minimum) and 1.0 m/hr (maximum) depending on the solid content.

Other Benefits

More than thousands of IPC have been installed worldwide since it is first introduced in northern europe in 70s. The technology has been localised for cost effective and practicality reasons. In potable water plants, IPC are designed and installed in modular approach for larger capacity. As it is fabricated in factory, both quality and ease of site installation can be complied to meet customer high expectations. It has also become a clarification process standard for many industrial effluent treatment due to its unique compact design and high performance solution. It simply works perfect without any mechanical parts. Our process engineers have years of experience to provide technical advice and solutions to your problems solving.



Note: All data are approximate and are subject to changed without prior notice. Inlet (N1) and outlet (N2) dimensions are nominal pipe size. All indicated sizes are in mm.