



Surface Aerator



L-2200A
Food Processing Plant

Superior Aeration Process

Surface aerators create an extremely flat and almost horizontal spray 360° around the unit. A direct driven highly efficient motor with optimized screw impeller draw the water from the bottom and sprays it back on the water surface.

The unique design of screw impeller has proven providing high aeration efficiency in field conditions due to maximum transfer of kinetic energy to water surface. This flow pattern also generates a full homogenization even in deep basins and on large surfaces such as lagoon.

Surface aerator is manufactured for its reliability and durability for extreme conditions operation. It can be installed in small tanks or massive lagoons. Draining of the tanks or lagoons is not required during any installation.



L-1500A
Food Processing Plant

Applications

- Activated Sludge Process
- Aeration Lagoon
- Sequencing Batch Reactor
- Equalization Basin
- Sludge Holding

Benefits

- Deep tank installation up to 5m SWD
- High oxygen transfer + dispersion
- Excellent mixing with no floc damage
- Simple installation + removal

Optional

- Draft tube
- Vertical guiding post
- Submersible mixer
- FRP Float
- Tensioning Spring

Surface Aerator Model Selection :

Model	Power	Rotational Speed	D	H	Weight	Standard Water Level	Max Water level with prolonged cone	High Turbulence Diameter	Complete Mixing Diameter
	kW	RPM	mm	mm	kg	m	m	m	m
L-550A	5.5	1460	1250	1711	217	2.6	3.6	9.5	15.0
L-750A	7.5	1460	1500	1878	244	2.8	3.8	10.0	16.0
L-1100A	11.0	1470	2000	2007	351	3.0	4.0	10.5	19.0
L-1500A	15.0	1465	2000	2214	369	3.2	4.7	11.5	24.0
L-1850A	18.5	1470	2000	2447	494	3.3	4.8	11.5	24.0
L-2200A	22.0	1470	2000	2605	514	3.4	4.9	12.0	25.0
L-3000A	30.0	1480	2000	2935	660	3.6	5.1	13.0	25.5
L-3700A	37.0	1480	2000	2943	759	3.8	5.3	14.0	26.0
L-4500A	45.0	1475	2300	3041	790	3.9	5.4	15.0	26.5
L-5500A	55.0	1475	2390	3393	1062	4.1	5.6	16.5	27.0

Note: All data are approximate and are subject to changed without prior notice. All dimension indicated are in metric unit.

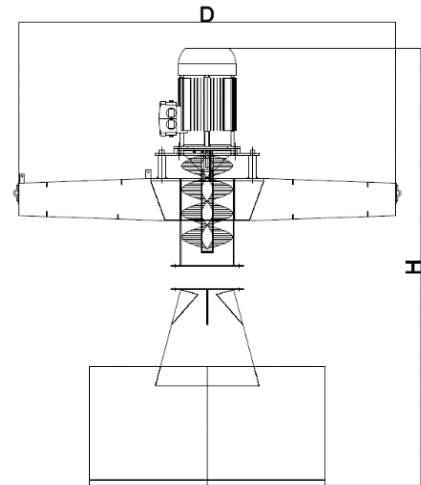
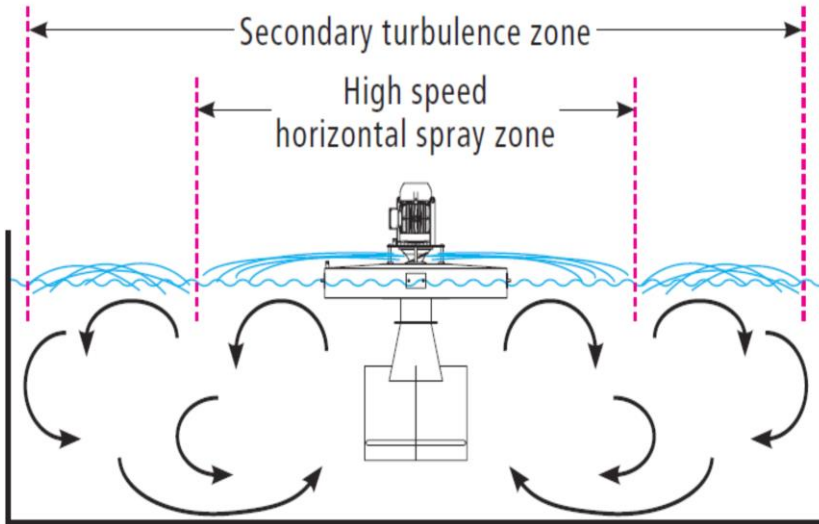

L- series surface aerator
Front View



2nos x L-750A
Cattle Farm



L-1500A
Food Processing Plant

Manufactured by:

ULTRASPAN

Designed by:

Level-21

No 5, Jalan Tambur 33/19, Seksyen 33, 40400
Shah Alam, Selangor, MALAYSIA

Berouw 150, 9000 Gent, BELGIUM

Telephone : +603 5131 0419

Email : sales@ultraspan.com.my

Website : www.ultraspan.com.my